

SRF GEN3 ENGINE REBUILD PROGRAM

All engine to be rebuilt **must have seals attached** when shipped to Enterprises. Unsealed engines will be refused unless prior approval is given.

General Procedures:

1. Fill out and sign this form. If the owner is responsible for unreasonable work delays or the engine is non-repairable, the engine may be forfeited. Keep a copy of this form for your records.

2. Preparation of engine:

Remove the following:

Both Manifolds	Fuel Rail and Injectors	Dipstick and Tube
Clutch	Alternator	
Oil Pressure Sender	Water Inlet	

DRESS ENGINE AS SHOWN

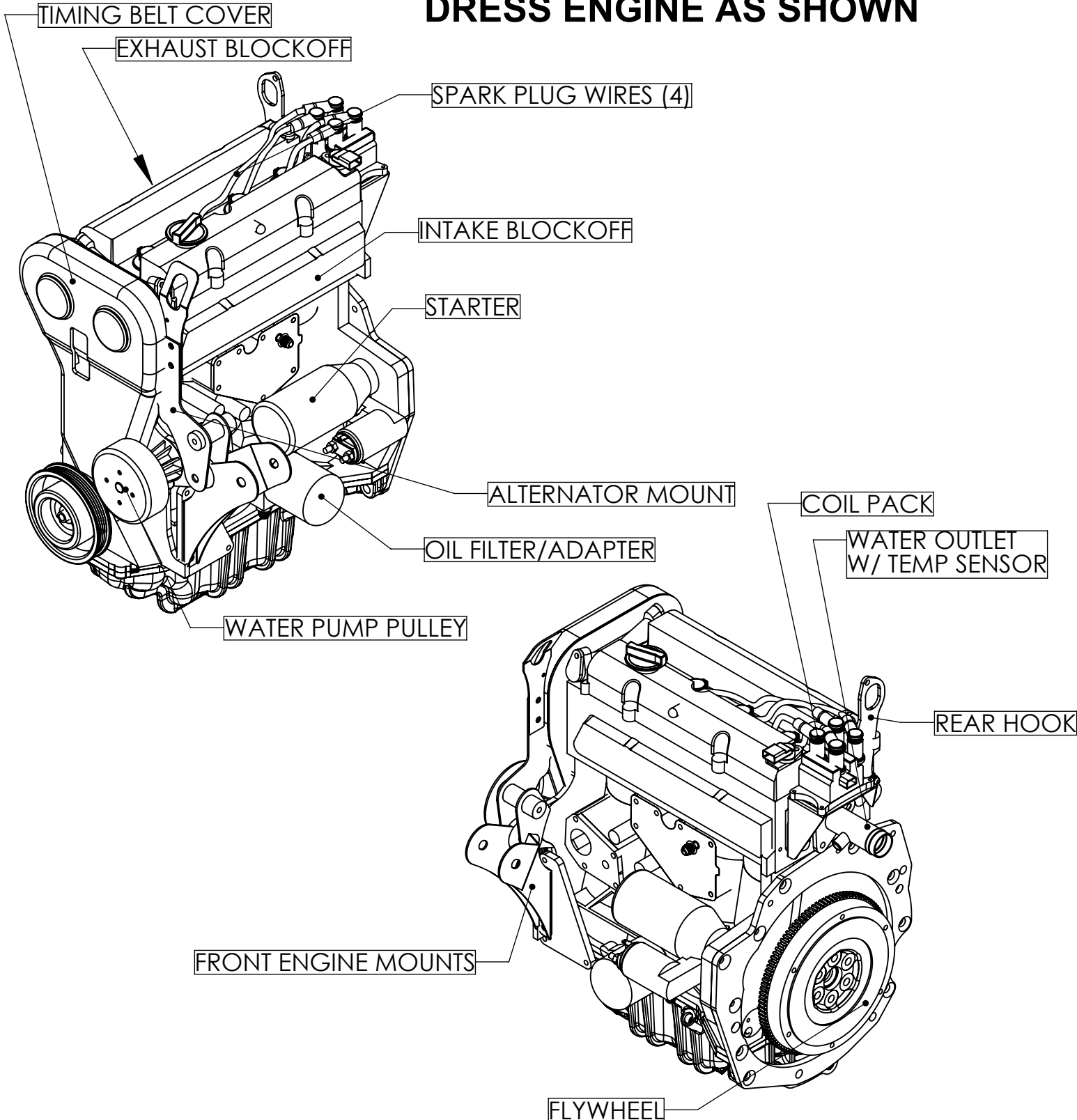

3. Crate the engine and ship **freight prepaid** to:

SCCA Enterprises, Inc.
14550 E Easter Ave, Suite 400
Centennial, CO 80112

To utilize Enterprises shipping discount you must contact Enterprises before shipping your engine. Send the engine on a 30" by 30" crate. Feel free to use custom shipping containers. You will get the same crate back provided it is in good condition, otherwise you may be charged for a new pallet and box top.

4. Enterprises will open and inspect the engine only when all paperwork is received. You will be consulted directly or through your CSR as to the recommended rebuild and costs. No work will be performed until authorization is received. If the customer chooses not to have the engine rebuilt, the core becomes the property of SCCA Enterprises, Inc. as payment for labor expended (no parts will be returned).

Engine Assembly & Shipment:

1. The engine will be tested on Enterprises' dynamometer and will be within established specifications.

Dyno readouts will not be released.

2. The engine will be sealed and a record will be maintained of engine and seal numbers.

3. All work will be performed to the highest standards. **There is no guarantee or warranty of any kind on a rebuilt engine.**

4. Upon completion of rebuild, dyno and receipt of payment, the engine will be re-crated for return shipment, either pre-paid or freight collect. Unusable crates will be replaced at the owner's expense. Enterprises and trucking companies will not consider open pallets suitable for return shipment.

5. Any engine not paid for within 30 days after notification of completion becomes the property of SCCA Enterprises, Inc.

FORM MUST BE RECEIVED AT ENTERPRISES BEFORE ENGINE REBUILD CAN START

Owner's name:

Daytime phone:

Best time to call:

CSR's name:

Billing: Bill CSR Bill Owner directly (CSR will receive appropriate credit regardless of billing choice)

Owner's billing address:

Return shipping address: (If different than billing)

Address: Residence Business

Lift gate needed: Yes No

Shipping: Pre-paid Collect

Delivery phone number:

Engine number:

Leak down or compression test results: 1. 2. 3. 4.

Has the engine been over-revved? Yes No

If yes, how many times:

Highest RPM:

Approximate time on engine Hours

Low oil pressure: Yes No

Please describe the conditions leading to a need for repair:

Once the engine is finished either the CSR or the owner will be contacted with the total amount due. Acceptable forms of payment are: VISA, Master Card, or Check. Engine will be shipped only when paid in full.

Owner's signature:

Date:

Notes: